

Design and manufacturing aspects of a vaginal speculum of antiquity, as investigated by computer tomographies

K.-D. Bouzakis^{a,*}, D. Pantermalis^b, K. Efstathiou^a, E. Varitis^a, N. Michailidis^a,
D. Sagris^a, I. Mavroudis^b, K. Vasteli^b, J. Kastner^c, D. Salaberger^c

^a *Laboratory for Machine Tools and Manufacturing Engineering, Mechanical Engineering Department, Aristoteles University of Thessaloniki, Thessaloniki, Greece*

^b *Archaeological Laboratories of DION, Aristoteles University of Thessaloniki, Thessaloniki, Greece*

^c *Upper Austria University of Applied Sciences, Steyr, Austria*

Received 7 November 2006; received in revised form 4 May 2007; accepted 13 May 2007

Abstract

This paper presents the investigation of a vaginal speculum, found during excavations in Dion, Greece, by means of computer tomographies. Based on this technique, the solid geometry of the structural elements of this medical instrument was reconstructed and a simulation of its operating mechanism was further conducted. Additionally important design and manufacturing data related to the vaginal speculum mechanism and its parts were obtained. The analysis provides various significant insights and further documents utilization of high level technical mechanical engineering procedures and technological sophistication in the Hellenic antiquity period.

© 2007 Elsevier Ltd. All rights reserved.

Keywords: Vaginal speculum; Computer tomography (CT); Solid modeling; Design; Manufacturing

1. Introduction

In the summer of 1993, excavations at Dion in the section of the ‘bronze hydraulis’ revealed a bronze vaginal speculum in an ancient workshop, shown in the upper part of Fig. 1 (Pantermalis, 1993). Its two dimensional representation as a mechanical drawing, based on conventional dimensions measurements and designing of artistic details, appears in the lower part of the figure.

The bronze speculum (Greek: *dioptra* (διόπτρα), Latin: *speculum magnum matrices*) has an overall length of about 220 mm and is comprised of a shaft having a thread in most of its length, ending into a T-shaped handgrip. The screw shaft goes through a cylindrical nut, the so-called “turtle”, with an

inner thread (screw nut). At the front of this screw nut, a small cylinder receives the perforated arms’ upper ends, thus forming a joint between each arm and the screw nut. The lower end of the screw shaft rotates interminably in a cylindrically shaped housing, being inside a bearing like base, located in the middle of a cross-bar, the arms’ connector. The axial movement of the screw shaft is restrained by a nail and an appropriate peripheral groove. On the backside of the arms’ connector there are appropriate sliding grooves to receive the two instrument’s arms that are secured by orthogonal shaped thin cover plates. By rotating the screw shaft clockwise, the arm’s connector is moved upwards to the screw nut, pushing at the same time the arms to slide into the appropriate grooves of the arm’s connector and thus to open. There are two stems fixed at the ends of the arms, and a third one in the middle of the arm’s connector. When the instrument is in closed position, the three stems form a symmetrical by rotation object with a variable diameter in successive cross sections along its symmetry axis, named “*priapiskos*”, or “*lotus*”. The latter

* Corresponding author. Tel.: +30 2310 996 079/996 021; fax: +30 2310 996 059.

E-mail address: bouzakis@eng.auth.gr (K.-D. Bouzakis).

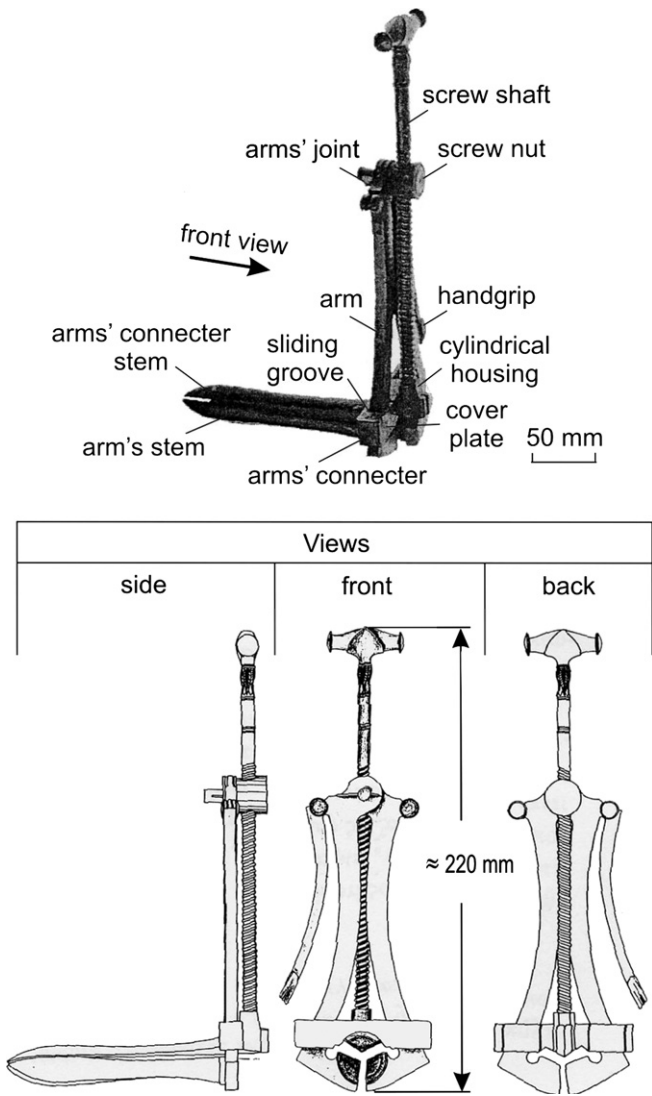

Fig. 1. The vaginal speculum, dated in 2nd century B.C., found during excavations in Dion.

is synonymous to clover, due to the three parts splitting, when the screw is rotating clockwise. Finally, at the upper end of the arms, two mobile handgrips are adapted. The right handgrip was not found in the excavations. Furthermore, the opening mechanism of the stems and of the left handgrip joint were found fixed by oxidation and thus neither the vaginal speculum operation could be visualized, nor the speculum be disassembled into its individual parts; thus the geometry of hidden technical details could not be registered.

A description of this ancient medical instrument (Deneffe, 1902; Longfield-Jones, 1986) appears in the now lost 17th chapter of the 4th book of Soranus, doctor of the 1st/2nd century A.D. from Ephesus. Soranus belonged to the famous School of Herophilus of Alexandria that had made impressive advances in medicine. The content of the chapter of Soranus is well known because of the Latin translation of Moschion (Milne, 1907). Another description survives in the works of Paul of Aegina (7th century A.D.) who was active in the main in Alexandria and preserved a chapter by Archigenes

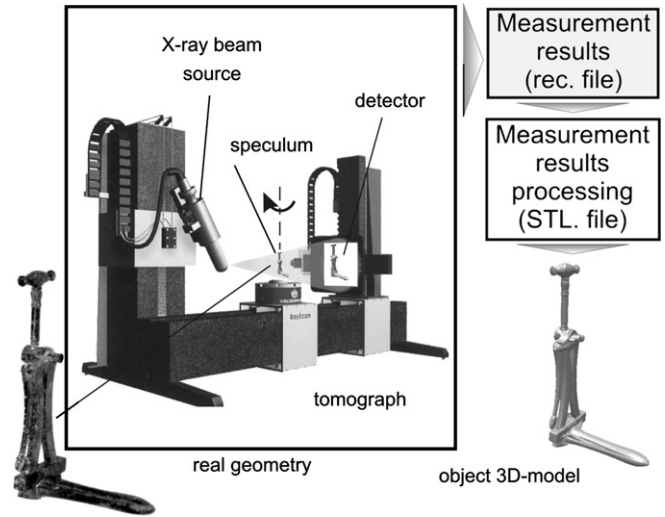

Fig. 2. Registering the 3D geometry of the vaginal speculum structural parts, in electronic files, by computer tomographies.

on abscess of the womb (Milne, 1907). Paul describes in details both the speculum and its use (book 6, part 7): The woman which was to undergo examination was tied to a chair and the doctor selected the appropriate speculum so that the



Fig. 3. The structural parts, of the vaginal speculum of Dion.

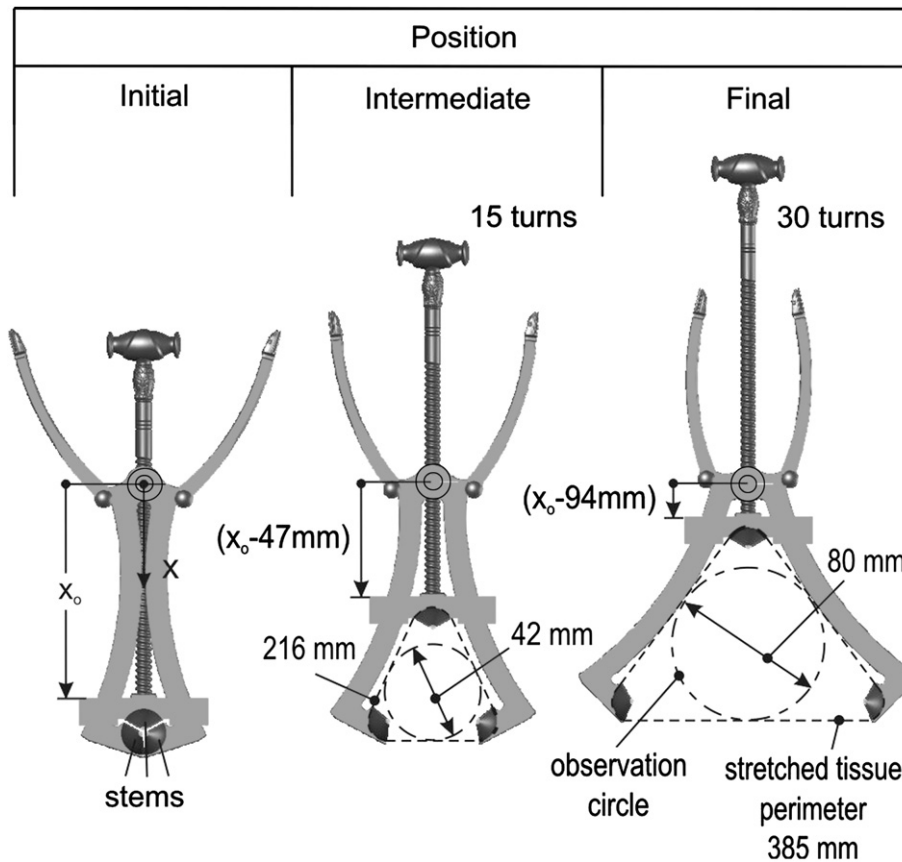

Fig. 4. Vaginal speculum mechanism in three characteristic operational positions.

womb would not be wounded, initially using a catheter. The speculum was inserted into the vagina by the doctor, who held the instrument by its handles. The screw shaft was carefully turned by the doctor's assistant. When the vagina had dilated, the doctor then removed the abscess. After the excreting the pus, gauze moistened with rose oil was used to ease the wound.

The speculum or dioptra of Dion is likened with those that were found at Pompeii (Bliquez, 1994) and is dated, most likely, to the 1st century A.D. It is still difficult to determine with certainty when this complex medical instrument was invented. The first question that must be answered is when the earliest application of the screw shaft in this form was used (Krug, 1984). It does not appear improbable that this is the instrument that was one of the inventions of the Alexandrian School of Medicine that promoted more than any other, the science of gynecology.

In order to investigate the design of the speculum of Dion and its parts, it was necessary to first record the precise solid geometry of the individual comprising structural elements. A precise and methodologically sound method for capturing an object's solid geometry is Computer Tomography (CT) (Bouzakis et al., 2005; Klein and Hering, 2004; Stereolithography, 2001). The vaginal speculum's solid geometry was recorded employing this method. Furthermore, technological details, revealing state of the art design and manufacturing practices in the antiquity, were investigated by applying

sections on the tomographies' electronic files, at various positions of the medical instrument.

2. Computer tomography and recording of the vaginal speculum's 3D geometry

Computer tomography is an innovative method used in many industrial, medical and other applications. Its advantage compared to scanning methods such as laser, CMM, etc., arises from its ability to record both the external and internal geometrical features of the object. A computer guided tomography and its working principle is presented in Fig. 2. Its main units are the source of radiation, which produces the X-rays (Roentgen) and the detector. The object under study is appropriately placed within the tomographer and multiple tomographies are performed, at successive revolving positions of the object, as this is rotated appropriately. The method is based on the measurement of X-radiation absorption in various directions. Applying appropriate mathematic algorithms, a map of radiation reduction is created versus the rotating position of the object. In this map, comparatively different densities of the object materials are indicated. After the conduct of a satisfactory number of tomographies, a data computer analysis is carried out, aiming at the restructuring of the object into external and internal surfaces. This results to a table, containing data of the so called voxels (volumetric elements), describing precisely the object's external and internal details. In

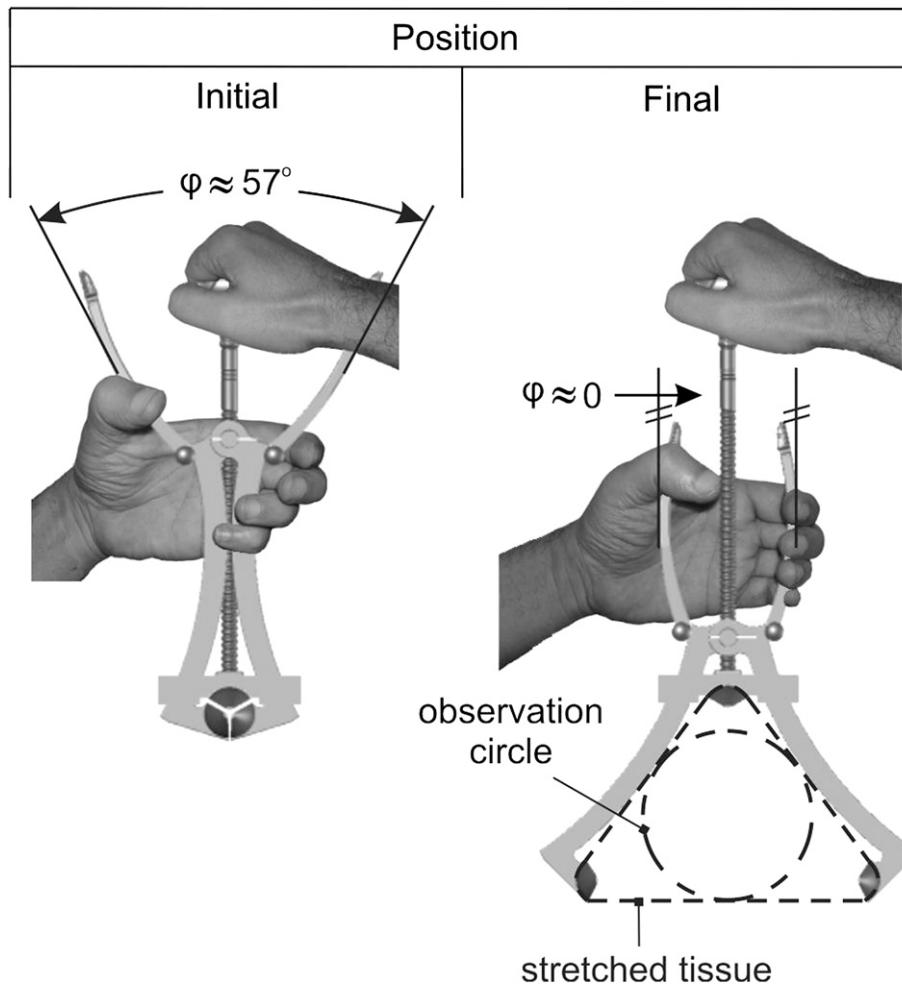

Fig. 5. Handling of the vaginal speculum.

this way, the 3D object geometry can be visualized and partial or full sections at any position of this geometry can be obtained.

For the speculum under investigation, an initial scanning was attempted employing a computer tomographer with power of 250 KVA and a recording resolution precision concerning of 10 μm . However, it was proven unsuccessful as the available power was not enough to penetrate within the object, due its thickness. For this reason, a second scanning of the object by a computer tomographer of a higher power (450 KVA) was conducted. In this case, all the internal shapes of the object were recorded with sufficient accuracy. That was not the case though for the artistic details, due to the decreased resolution of this tomographer, amounting to 200 μm . The negative correlation of power and resolution can be explained by the larger scattering of the enhanced X-ray power in the specimen material, compared to the tomography at a lower power level.

Furthermore, to record the speculum's parts solid geometry, the produced STL-file (STereo Lithography) was used by processing the measurement results file, that is of the rec. file as shown in Fig. 2. Through the STL-file, it was not possible to export and isolate the individual parts of the object. For this

reason, the parts composing the vaginal speculum were designed by means of a CAD-system, considering conventional dimensions measurements results. These were further checked for geometrical precision, taking into account the measurements of the tomographer; when discrepancies were identified, appropriate corrections according to the files of the tomography were made. The individual parts of the speculum are illustrated in Fig. 3, as an explosion drawing. Most of these parts have a particularly complex solid geometry. Moreover, Fig. 3 reveals how the individual parts are assembled together. The vaginal speculum consists of 15 parts, 11 of which are different from each other. Parts that are not visible as well as parts with hidden internal shapes are included among them. Additionally, a number of artistic decorations, which were difficult to be recorded, appear at the external surface. The end of the handgrip has the form of a snakehead, symbol of Aesculapius (Bliquez, 1994) as well as the screw below the handgrip the shape of leaves. These artistic details were designed at a second processing stage, by an innovative method, based on digital photography of the real object (Bouzakis et al., 2005). According to this procedure, the region to be copied is photographed and then imported in the 3D model with the aid of specialized software while regions of different

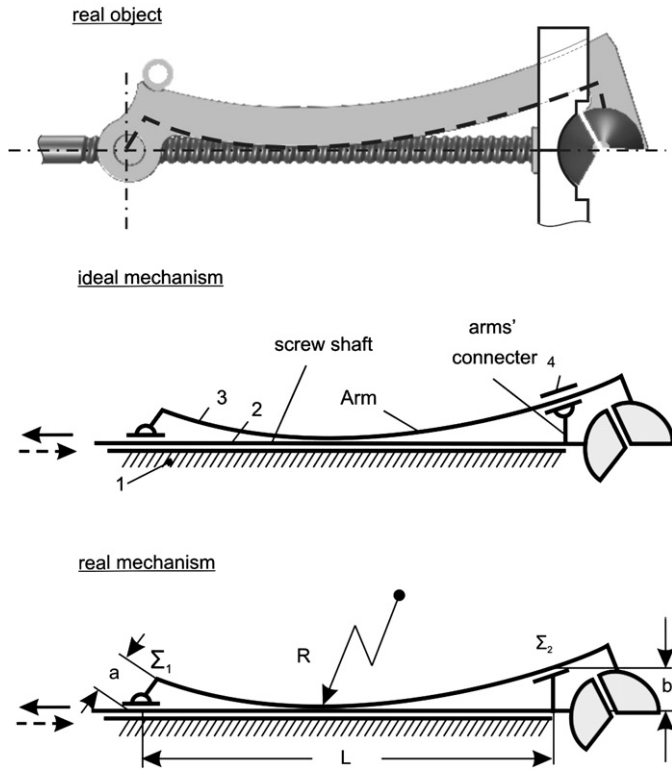

Fig. 6. Vaginal speculum stems opening mechanism.

contrast are imprinted with proportionally different depth. The working principle of this methodology is based on the contrast of the object concrete regions.

3. Visualization of the vaginal speculum operation

As the opening mechanism of the stems and of the left handgrip joint were found blocked, the vaginal speculum

operation could not be visualized. Therefore to explain the operation and the handling of this medical instrument, a computer supported simulation of its kinematics mechanism was developed.

Fig. 4 illustrates three different operating positions of the investigated medical instrument. The corresponding calculations were performed using the computer supported kinematics simulation of the vaginal speculum mechanism. In the initial position, the stems are closed. The intermediate position corresponds to 15 turns of the screw shaft, or to a movement of the arms' connector towards the screw nut of about 47 mm. The dashed line represents the stretched tissue. The stretched tissue perimeter STP in this position amounts to 216 mm. The final position corresponds to the maximum tissue stretching, achieved by 30 turns of the screw shaft, or an axial arms' connector movement of approximately 94 mm. In this final position the STP amounts to ca. 385 mm. The observation circle diameter OCD in the intermediate position is about 42 mm, whereas in the final one amounts to ca. 80 mm. A modern vaginal speculum, has an OCD of approximately 50 mm.

As far as the actual handling of the instrument is concerned, the operator held it with the one hand and with the other hand rotated the screw shaft. In the initial and the final position, the instrument was retained as indicatively displayed in Fig. 5. During the stems' opening procedure, the angle between the handgrips decreases, as exhibited in the figure. One can assume that the fracture of the right handgrip, which was not found during the excavations, is due to the unintended handgrip joint overloading by the operator, perhaps caused by an intense movement of the patient under medical investigation. Furthermore, if the operator had removed his palm from the T-shaped handgrip of the screw shaft, as discussed later, the screw shaft was immobilized, without losing its tightening.

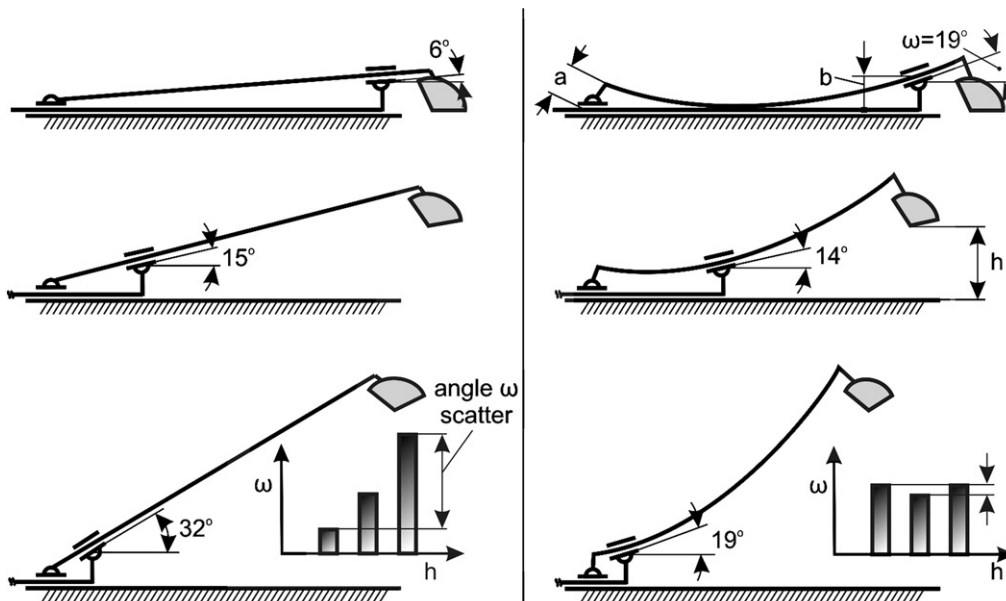

Fig. 7. The scatter of the rotational angle ω of the arm slider in the case of a straight and a bended arm.

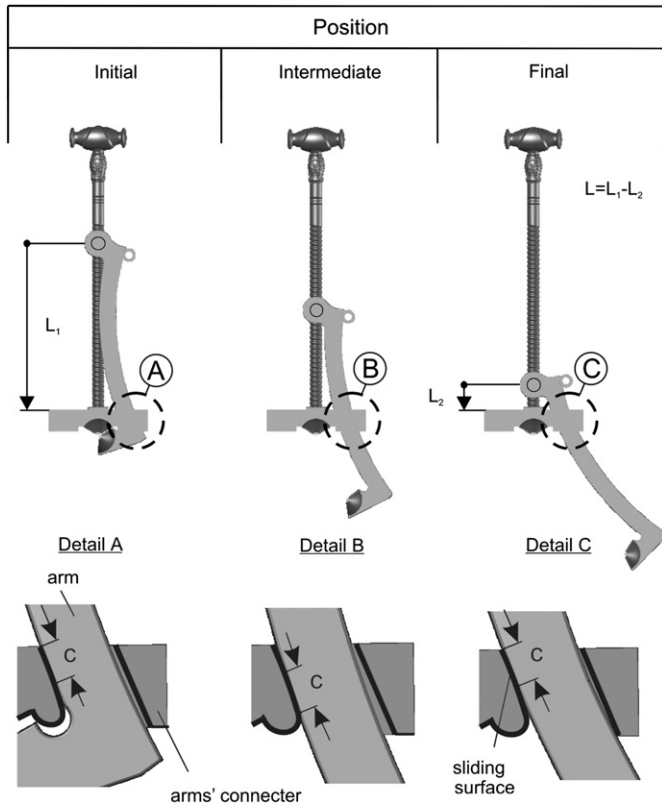

Fig. 8. Contact length c between the arm and the arms' connector in the sliding region.

4. Investigation of the vaginal speculum's design and manufacturing

4.1. The lay out of the stems' opening mechanism

The stems opening mechanism is explained in Fig. 6. The ideal mechanism is a 2D plane one comprised of four links.

Link 2, the screw shaft, conducts a horizontal movement along a slider, placed in the mechanism frame 1, which represents the screw nut. Link 3, one of the instrument's arms is connected with 2 by the arms' rotational joint in the front of the screw nut and its other end, through the slider 4 with link 2. Slider 4 had to rotate around a joint, located on the link 2. To keep things simple, slider 4 rotation was omitted and link 3 can slide in the appropriate grooves of the arms' connector, as demonstrated in the sketch of the real mechanism at the bottom of Fig. 6. This though causes contact problems to the collaborating surfaces of link 3 and sliding grooves of the arms' connector; to overcome them the arms were both bended. As demonstrated in Fig. 7, if the arms were straight, the rotational angle ω of the slider 4 would increase continuously and in this way a rotational joint between slider 4 and link 2 would had been indispensable. On the other hand, the scatter of rotational angle ω in the case of a rounded (bended) arm, is too small, thus, rendering the rotational joint between slider 4 and link 2 practically unnecessary. Taking these into account, the stem's opening mechanism of the vaginal speculum was simplified, without creating contact problems between the arm and the arm's connector in the sliding groove.

At the upper part of Fig. 8 three positions of the mechanism are illustrated: the initial, an intermediate and the final one, as well as the corresponding slider contact length c , between the arm and the slider in the arms' connector sliding groove (see bottom part of the figure). The contact length between the curved surfaces of the slider and the arm, was intended to be as large as possible, to reduce the superficial mechanical loads and thus the consequent wear. Throughout the moving length L of the screw shaft, a satisfactory convergence of curvatures of the slider surface with the collaborating convex surface of the arm is achieved. This results from the relative contacts between the corresponding surfaces of the arms' connector grooves and the arms demonstrated in the details at the bottom part of Fig. 8. The contact width c remains practically constant throughout the length L of the arms' connector

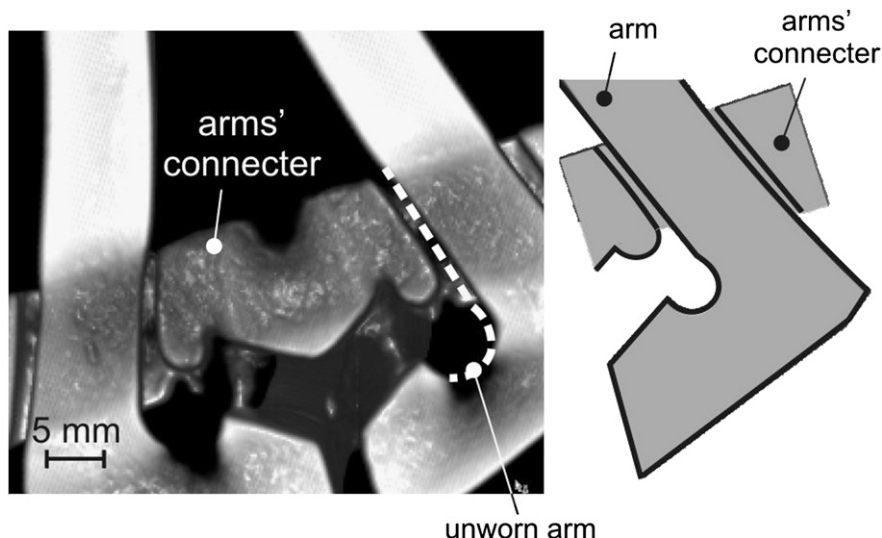

Fig. 9. Vaginal speculum arm in the arms' connector sliding region, as registered by computer tomography.

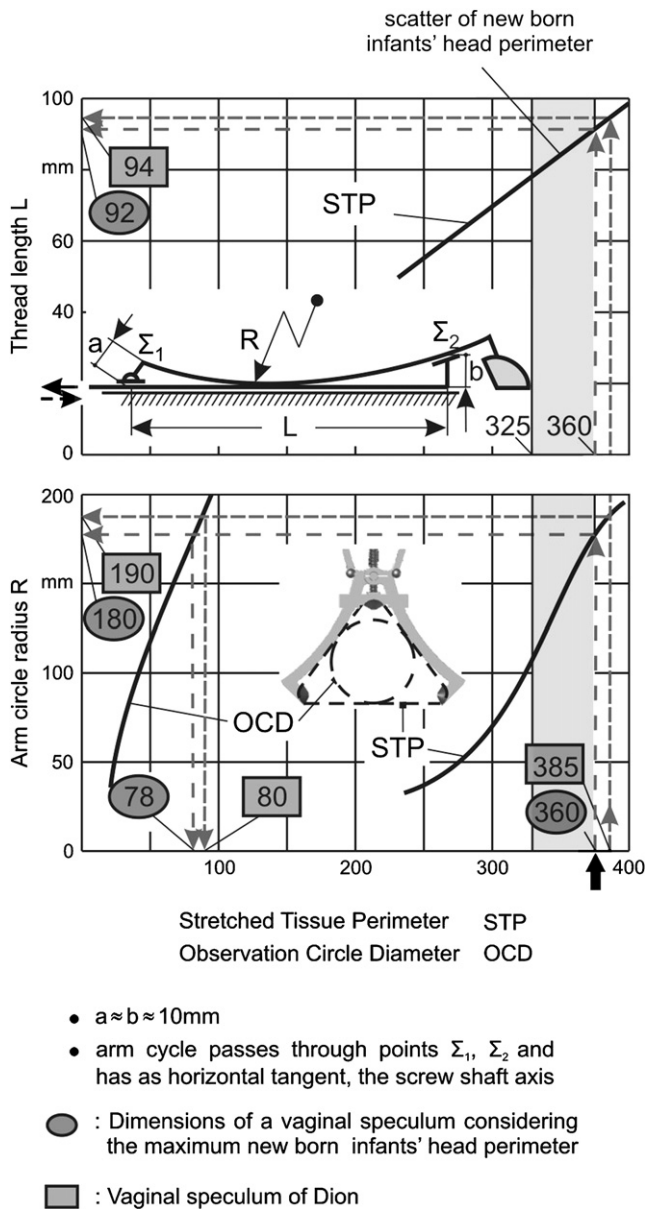

Fig. 10. Arm radius and thread length of the vaginal speculum versus the perimeter of the stretched tissue and the observation circle diameter.

movement towards the screw nut. A growth of dimensions a and b , or a decrease of the arm radius R leads to a considerable reduction of the contact width c .

The computer tomography exhibited in Fig. 9, corresponds almost to the initial position of the vaginal speculum mechanism and demonstrates the convergence of the collaborating arm's connector groove and surfaces. This further reveals that the previously described dependencies concerning the effect of dimensions a , b and R on the contact width c should had been considered during the layout of the vaginal speculum mechanism.

Due to design and manufacturing reasons of the arms' joint and connector, the dimension a (see Fig. 6) cannot be less than ca. 10 mm. On the other hand, the distance b has to be kept also small, for reasons already explained. To allow an

adequate operation of the mechanism, fulfilling the desired opening requirements of the stems, the thread length L of the screw has to be prescribed and then the arms' curvature radius R , can be geometrically determined, taking into account that initially, when the stems are closed, the arms practically have a common horizontal tangent, which is the screw shaft axis. For a given screw length L , the arm radius R is defined so that the relative circumference passes through points Σ_1 , Σ_2 and has as horizontal tangent, the screw shaft axis.

A basic information essential for determining the screw thread length L and designing the vaginal speculum's mechanism, is the opening size of the stems. Based on statistical medical data, it is known that the perimeter of the head of newborn infants vary from 325 to 360 mm. Considering these data, one can conclude that due to physiological reasons the mechanism should not overcome this bound, i.e. it is not allowed to stress the tissue at a perimeter (STP), larger than 360 mm. With this remark we do not claim that the speculum was used to facilitate childbirths, but that in its design physiological limits had been considered.

The screw thread length L and the arms' radius R versus STP are shown in Fig. 10. The dependency of the observation circle diameter OCD by the arm circle of radius R , passing through the points Σ_1 , Σ_2 and having as horizontal tangent the screw shaft axis is also demonstrated in the same figure. The appropriate calculations were conducted by the developed computer supported simulation of the medical instrument's mechanism kinematics. Furthermore, the scatter of the newborn infants' head perimeter is displayed in the diagrams of Fig. 10. The maximum head perimeter dimension of 360 mm leads to the determination of a thread length L of 92 mm and respectively, to an arm radius R of 180 mm corresponding to a maximum OCD of 78 mm. The mechanism of the investigated instrument found in Dion, has approximately the same dimensions, i.e. for the determined maximum observation circle diameter of 80 mm as already demonstrated in Fig. 4, the arm radius R amounts to 190 mm and the screw thread length L to 94 mm.

4.2. Screw shaft thread design

Several geometrical data of the vaginal speculum screw shaft and its thread are displayed in Fig. 11. The thread has an external diameter D of 7.9 mm and a pitch t of about 3.1 mm, corresponding approximately to the value of π . The thread helix angle α can be calculated by the equation:

$$\alpha = \text{atan}(t/(\pi D)) \tag{1}$$

where in the present case, due to the fact that $t \approx \pi$ and $D \approx 7.9$ mm, α is equal to 7.2° .

The angle β between two thread flanks, through measurements determined, amounts to approximately 120° .

By analyzing the forces acting on the thread flanks (see Fig. 12) when the instrument's operator had removed his hand from the screw shaft handgrip, the reaction forces F and F_u develop on the screw nut, resulting from the forces

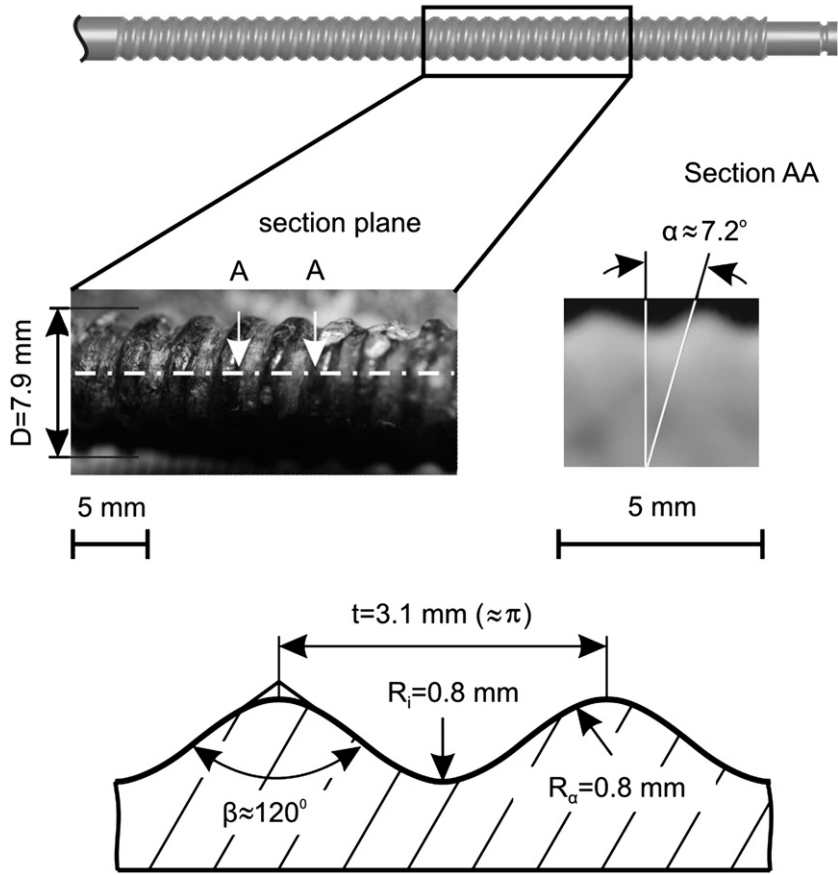

Fig. 11. Screw shaft photograph and longitudinal CT-section with main thread data.

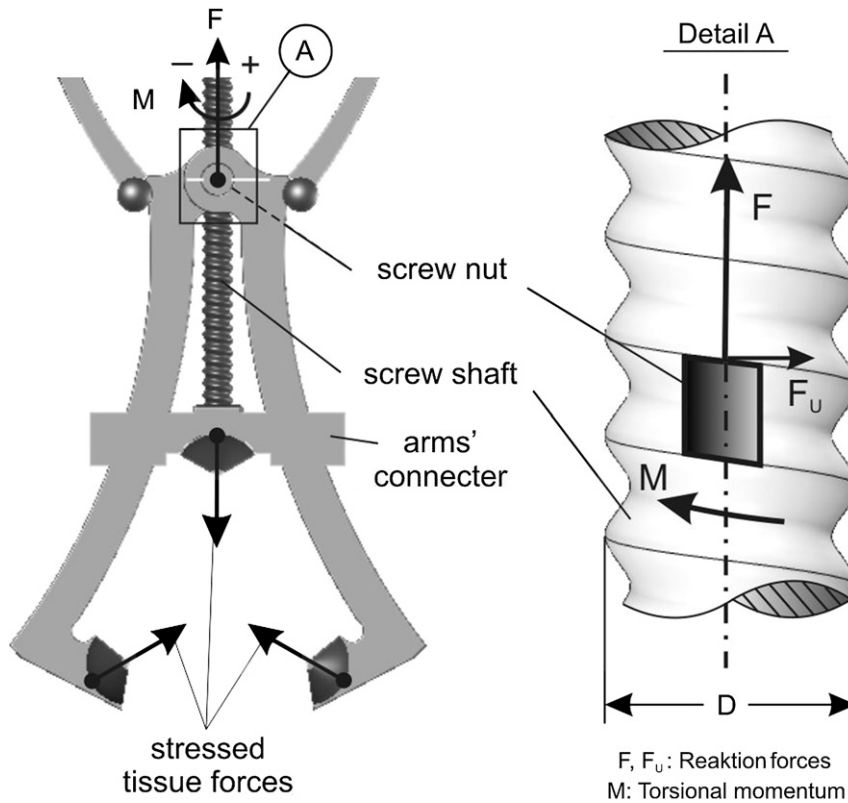

Fig. 12. Forces and torsional momentum acting on the thread flank, when loading only by the stressed tissue.

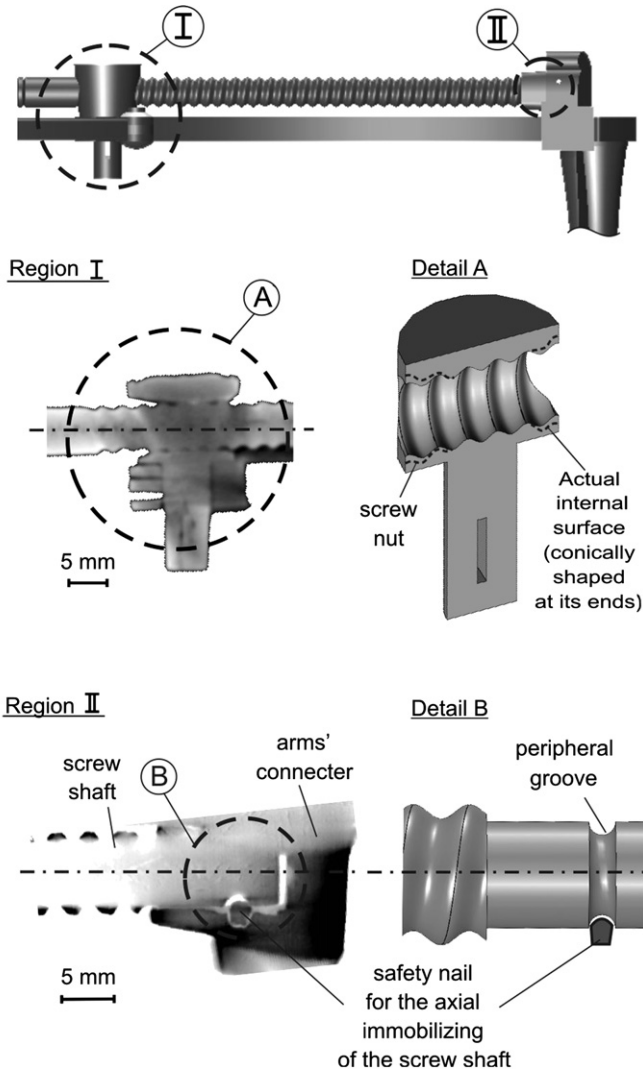

Fig. 13. Invisible geometrical details, detected by computer tomographies.

applied by the stretched tissue on the instrument stems. These forces attempt to close the stems' mechanism, i.e. to push the arms' connector downwards through the screw shaft. The developed reaction forces F and F_u can be computed as described in Bouzakis et al. (2005).

If the circumferential reaction force F_u produces a torsional momentum M acting on the screw shaft, which is negative or zero (Niemann, 1975), then a screw shaft rotation cannot occur, i.e. the screw shaft is immobilized (self-tightening), if the operator had removed his palm from the T-shaped handgrip of the screw shaft and only the stems are pressed by the stretched tissue. This condition is always valid in the investigated case of the speculum of Dion, due to the appropriate selection of the thread helix angle α and the thread flank angle β . An analytical description is provided in Bouzakis et al. (2005).

4.3. Characteristic design details of the screw shaft and the screw nut

The cross section of the screw nut and the arms' joint can be observed in the tomography and in the corresponding sketch in

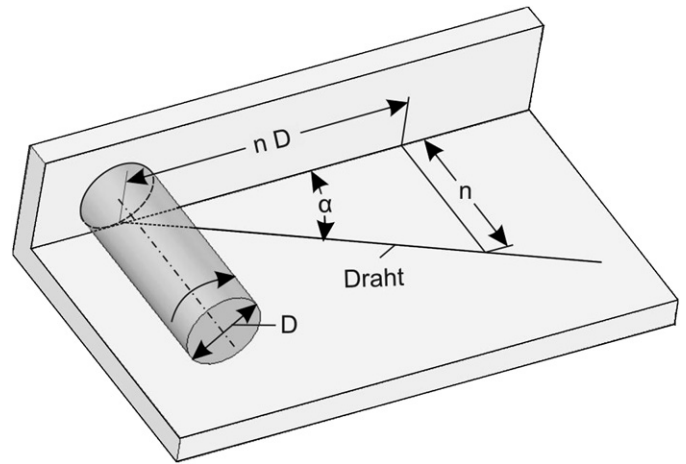

Fig. 14. Imprinting the thread helix trace on the cylindrical surface of a shaft wax model.

the middle of Fig. 13 (region I). It is obvious that the upper and the lower part of the screw nut are shaped conically, in order to facilitate the assembly and the gradual smoothing of the thread flanks roughness at the beginning of the collaboration between the screw shaft and the nut. Moreover, Fig. 13 illustrates a section, also obtained by computer tomography, approximately in the middle of the vaginal speculum arms' connector (region II), where the screw shaft ends. Information regarding the assembling of the screw shaft end with the arms' connector can be obtained from this section, which could not be extracted by any other non-destructive method. It appears that the screw shaft has an appropriate peripheral groove, which by a safety nail, immobilizes the screw shaft axial relative movement towards the arms' connector. The screw shaft end has a smaller diameter than the thread, due to the fact that during the assembly it has to pass through the screw nut first.

4.4. Manufacturing of the screw shaft

A very interesting aspect is the thread manufacturing by a wax model of the screw shaft, considering the techniques existing in the antiquity. If it is taken into account that the thread pitch t amounts to approximately $(t \approx \pi)$, as already captured in Fig. 11, the thread could be formed very easily on a wax cylinder of diameter D , corresponding to the exterior diameter of the screw shaft, by means of the procedure captured in Fig. 14. In this arrangement a filament is placed at an inclination angle α , as demonstrated in the figure. The angle α is adjusted, considering the dimensions nD and n , whereas n is an ordinary and conveniently large integer. The length n is expressed in the same unit system as the diameter D . Then the angle α amounts to:

$$\begin{aligned} \alpha &= \text{atan}(n/(nD)) = \text{atan}(1/D) = \text{atan}(\pi/(\pi D)) \\ &= \text{atan}(t/(\pi D)) \end{aligned} \quad (2)$$

i.e. this angle is equal to the thread helix angle, according to Eq. (1).

By rolling, without sliding, the wax cylinder from left to the right, for example on a corner shaped platform, which serves as a guide, a trace was imprinted by the filament on the cylinder surface, thus forming the desired thread helix. Then a craftsman following this trace, shaped carefully the thread gap.

5. Summary and conclusions

Innovative technologies such as the computer tomography, allow the precise recording of the solid geometry and further facilitate the investigation of manufacturing and operation of ancient objects. In this research, a complex vaginal speculum found in excavations in Dion was investigated, via X-ray computer tomographies. The three dimensional model based on such tomographies of the vaginal speculum, allowed the simulation of the mechanism kinematics of this medical instrument and thus the analysis of its layout, the visualization of its operation and the investigation of its manufacturing procedures. Taking into account the obtained results, significant operational, design and manufacturing insights were obtained revealing an impressively high technical sophistication in the Hellenic antiquity.

Acknowledgments

The presented research was conducted within the frame of the “Archaeocop” EUREKA project supported by the General Secretariat for Research and Technology of the Hellenic

Ministry for Development. The authors would like to thank Prof. Klein and his collaborators for their assistance in scanning the vaginal speculum by a computer tomographer of 250 KVA power.

References

- Bliquez, L.J., 1994. Roman Surgical Instruments and Other Minor Objects in the National Archaeological Museum of Naples, Mainz.
- Bouzakis, K.-D., Pantermalis, D., Efstathiou, K., Varitis, E., Michailidis, N., Mavroudis, I., 2005. Archaeological objects solid geometry determination based on computer tomographies, digital photography and appropriate processing of the related data, Proceedings of 2nd International Conference on Manufacturing Engineering ICMEN, 5–7 October 2005, Halkidiki-Greece, ZITI Editions Thessaloniki, pp. 675–694.
- Deneffe, V., 1902. *Le speculum de la matrice a travers les ages*, Anvers.
- Klein, F., Hering, E., 2004. Opening lecture of the conference: “Anwendungen der 3D-Computertomographie in Archaeologie, Restaurierung und Kunstgeschichte“, Aalen, Germany.
- Krug, A., 1984. *Heilkunst und Heilkult: Medizin in d. Antike*, München.
- Longfield-Jones, G.M., 1986. A Graeco-Roman Speculum in the Wellcome Museum, *Medical History* 30, pp. 81–89.
- Milne, J.S., 1907. *Surgical Instruments in Greek and Roman Times*, London (Reprinted 1970 by August M. Kelley Publishers, New York).
- Niemann, G., 1975. *Maschinenelemente Band I*. Springer Verlag.
- Pantermalis, D., 1993. Dion excavations in 1993 and the cupreous speculum. In: *The Archaeologic Work in -Macedonia and Thrace*, Vol. 7. Ministry of Culture – TAP, Aristoteles University of Thessaloniki, pp. 195–198 (in Greek).
- Stereolithography, 2001. *Stereolithography – as Easy as Operating a VCR*. 3D@work. Informazine 3D Systems, 1/2001.